

REV	DESCRIPTION	DRAWN	DATE

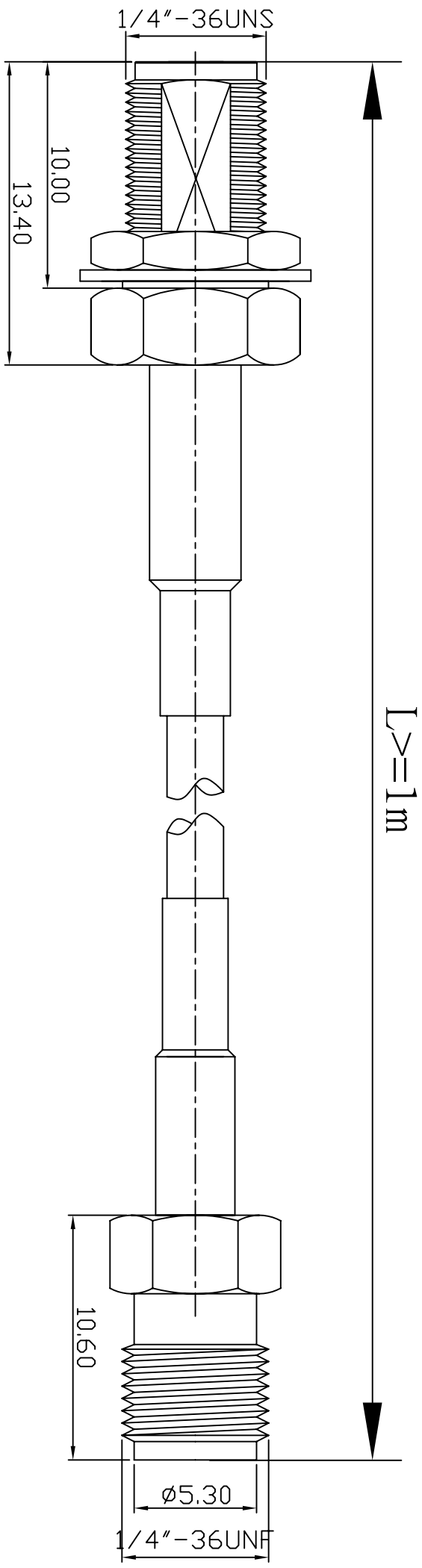

L >= 1 m

NO	Description	Qty	Material	Finish
3	SMA-1012-7-L-TGG	1	BRASS	GOLD
2	RG174/RG316/LLC100	1		
1	SMA-1012-7-L-TGG	1	BRASS	GOLD

UNLESS OTHERWISE SPECIFIED		*MAJOR DIMENSION	
1 REMOVE ALL BURRS		UNLESS OTHERWISE	
2 BREAK ALL CORNERS & EDGES TO 1.5 MAX.		NOTED TOLERANCES	
3 CHAMFER 1ST & LAST THREADS 45°		0.5-6 = ±0.2	
4 DIAMETERS ON COMMON CENTERS TO BE CONCENTRIC WITHIN DIMENSIONS ARE AFTER PLATING.		6-30 = ±0.4	
		30-120 = ±0.6	
		120-315 = ±1.0	
		ANGLES = ±1°	

APPROVED	CHECKED	DRAWN
		ARNQ

SCALE	4/1	UNIT	MM
-------	-----	------	----

DRAWN DATE	03/06/21
------------	----------

FILE NO.	D:\DWG\SMA1012-SMA1012\12127\174\316\100\10127-AL
----------	---------------------------------------------------

華耀科技有限公司 <i>Hua Yao Technologies co., Ltd</i>	
TITLE	SMA1012 - MM CX802
DRAWING NO.	12127/174/316/100/10127-AL
REV	A